

# Refrigerant Float Switch

Product Bulletin 61-11 B

Type: LLSS

Working Pressure: 31 bar (450 psig)



## Purpose:

The LLSS refrigerant float switch provides an electrical switching action in response to change in the refrigerant level. Flooded surge drums, flooded shell and tube chillers, high and low pressure receivers, intercoolers, transfer vessels and various kinds of accumulators are just some of the locations LLSS float switches are used to control and monitor liquid levels. The LLSS's most beneficial features are its stainless steel construction, which allows it to withstand corrosive environments and its overall light weight minimizes installation costs.

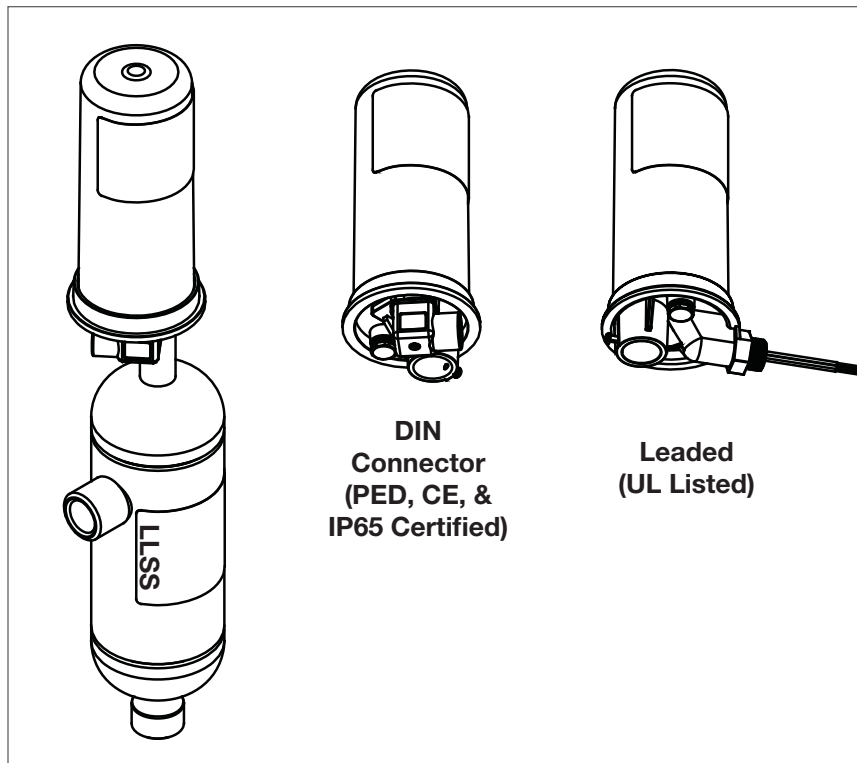

## Contact Information: Product Features:

Parker Hannifin Corporation  
**Refrigerating Specialties Division**  
2445 South 25th. Avenue  
Broadview, IL 60155-3891

**phone (708) 681-6300**  
**fax (708) 681-6306**

[www.parker.com/refspec](http://www.parker.com/refspec)

- Suitable for Ammonia, R-22, R-507, R-134a, and other common refrigerants
- Interchangeable with current R/S float switches
- Magnetically actuated switch
- UV resistant and transparent switch housing
- Stainless steel float chamber assembly
- Single pole double throw switch
- Float switch tank weighs 2.27 kg (5.0 lbs)
- Moisture preventing membrane
- Complies with Pressure Equipment Directive (PED) 97/23/EC (DIN connector only)
- Switch
  - UL listed – leaded switch
  - CE certified – DIN switch



Patent Pending

ENGINEERING YOUR SUCCESS.

**Description**

The LLSS Refrigerant Float switch is a mechanical float device which indicates a particular level of refrigerant in a vessel. It consists of a stainless steel welded chamber containing a float on the inside with a limit switch mounted on top. The chamber has a float-rod assembly inside with a metallic attractor located on the upper end of the rod. As the level in the system rises, the liquid fills the chamber causing the float ball to rise. The rising float with the attractor comes in close proximity of the magnet located inside the switch assembly. The magnet is mounted on a lever that operates a snap action switch. The switch can turn an electrical circuit on or off.

The Float Switch is used to open and close solenoid valves, to activate or

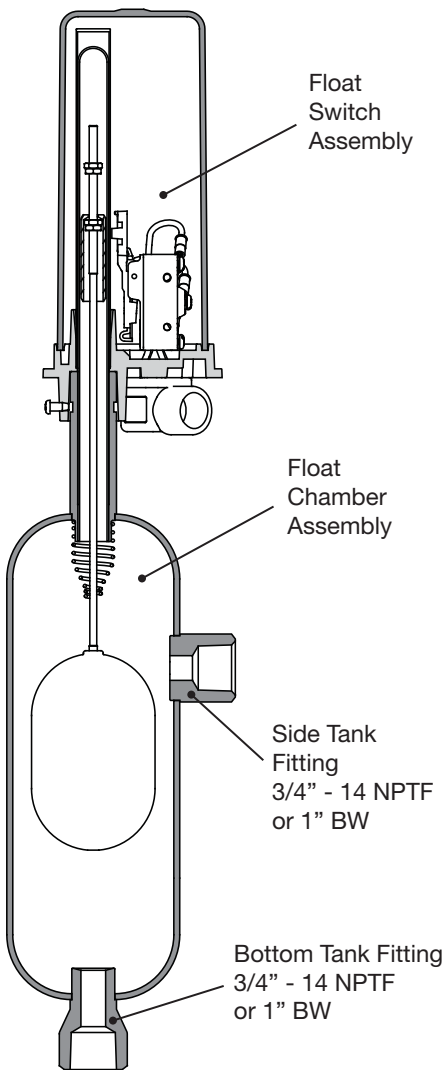

**Float Switch Cross-Section**

de-activate electrical controls, to energize or de-energize magnetic starters for starting and stopping refrigerant liquid pumps and compressors, and as a safety device, to sound alarms and turn on lights when there is high or low liquid level.

The electrical switch and operating mechanism are encapsulated within a UV resistant transparent housing. A pressure equalizing membrane is used to protect the switch from water, dust, dirt, and most oils from entering the enclosed housing.

This Refrigerant Float Tank can be used with all common refrigerant liquids with specific gravity of 0.57 to 1.7 in a temperature range of -75°C to 65°C (-100°F to 150°F).

**Principles of Operation**

When the float chamber is empty, the float ball will be supported by the upper cushion spring, at rest the float ball does not contact the tank. In this position, the metallic attractor is out of the magnetic field and the lever and magnet is away from the enclosing tube. With the lever and magnet in this position, the electrical switch will have one set of contacts open (N.O. - electrical circuit open) and the other set of contacts closed (N.C. - electrical circuit closed).

As liquid refrigerant enters the chamber through the bottom inlet connection, the float will start to rise as it is buoyed-up by the liquid. As the float and its rigidly attached float rod begin to move upward, the metallic attractor stop nuts will contact the metallic attraction sleeve and move it upward.

As the liquid level continues to rise in the float chamber, the float and float rod will continue to move upward until the metallic attractor moves into the magnetic field and attracts the magnet and lever towards the enclosing tube. With the magnet in this position the normally closed circuit will open and the normally open circuit will close.

The neck at the top of the chamber and the metallic attractor sleeve provide a means for guiding the float rod. This

design feature virtually eliminates internal sludge or oil formation on the chamber side walls from affecting the float's freedom of movement.

If a violent surging action should take place in the main vessel, the resultant rapid change in liquid level might be reflected in the float chamber, although at a much slower rate due to the inlet connections.

A rather sudden increase in liquid level could possibly raise the float and float rod up past the normal operating liquid level and cause the float ball to contact the upper stop spring. The upward movement of the float and float rod would now be stopped. This upper spring eliminates possible damage brought about by an abrupt inflow surge.

The electrical switch has single pole double throw contacts. The 3 leads from the switch are connected to isolated terminal pins incorporated into the base. For both the DIN connector and leaded switch, the wires are color coded and individually tagged as follows (in addition each wire is marked as shown in parenthesis):

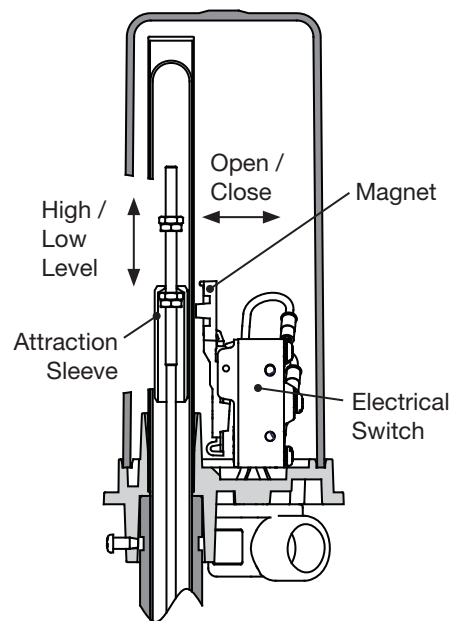

**Switch Cross-Section**

**Green Wire**

Ground lead (G)

**Gray Wire**

Common lead (C)

**Red Wire**

Normally closed circuits (N.C.)

Makes a closed electrical circuit (with magnet and lever away from the enclosing tube) between the red and gray wire when the liquid level is low.

**Black Wire**

Normally Open (N.O.)

Makes an open electrical circuit (with magnet and lever away from enclosing tube) between the black and gray wire and the liquid level is low.

**Pipe Column Installation**

The pipe column should be installed as shown in the float tank nameplate and refrigerant level location diagram. The position and orientation of the column must be appropriate to the specific application and installation criteria. The pipe column must always be in a vertical position. In any case, it must be in a serviceable location and out of the way of any possible damage

by material handling vehicles such as lift trucks.

The Refrigerant Float Switch is shipped from the factory with a plastic plug in the bottom and side tank fittings. This pushes the float ball and float rod into the upper position. This keeps the float ball from bouncing and possibly being damaged in shipment. Unpack carefully and check the carton to make sure all items are unpacked.

Do not remove the protective coverings from the inlet and outlet of the switch until it is ready to be installed. Protect the inside of the switch from dirt and chips before and during installation

The desired high level in the surge drum, accumulator, shell and tube evaporator, receiver, etc., should be established and located on the vessel or switch column (if supplied). The refrigerant float switch should be located so that the level mark shown on the nameplate is lined up with the desired high liquid level in the vessel, based on the fluid temperature and specific gravity. The low level will be two inches below the high level.

The gas equalizing connection located on the top side of the float chamber should normally be connected well

above the liquid level in the vessel upon which it is mounted. The piping for making this connection should never be “trapped” as any liquid contained therein will cause the upper part of the float chamber to become gas-bound.

The liquid connection located at the bottom of the float chamber should be piped to the vessel at a location preferably lower than the float switch in such a manner that it will allow the pipe to be free draining thereby offering no obstructions to gravity flow. DO NOT TRAP THIS LINE as it would then become an ideal location for oil to accumulate and could cause false levels in the float chamber. It would be ideal if the piping on this liquid connection were arranged so that liquid could drain freely back into the vessel. Since this is not usually practical, level horizontal connections are normally used. Make both the liquid and gas equalizing pipe connections as short as possible.

The LLSS can be installed in ambient temperatures of -45°C to 50°C (-50°F to 120°F).

Remove the switch from the stainless steel body before welding. This grade of stainless steel is a poor conductor of heat and conventional weld processes

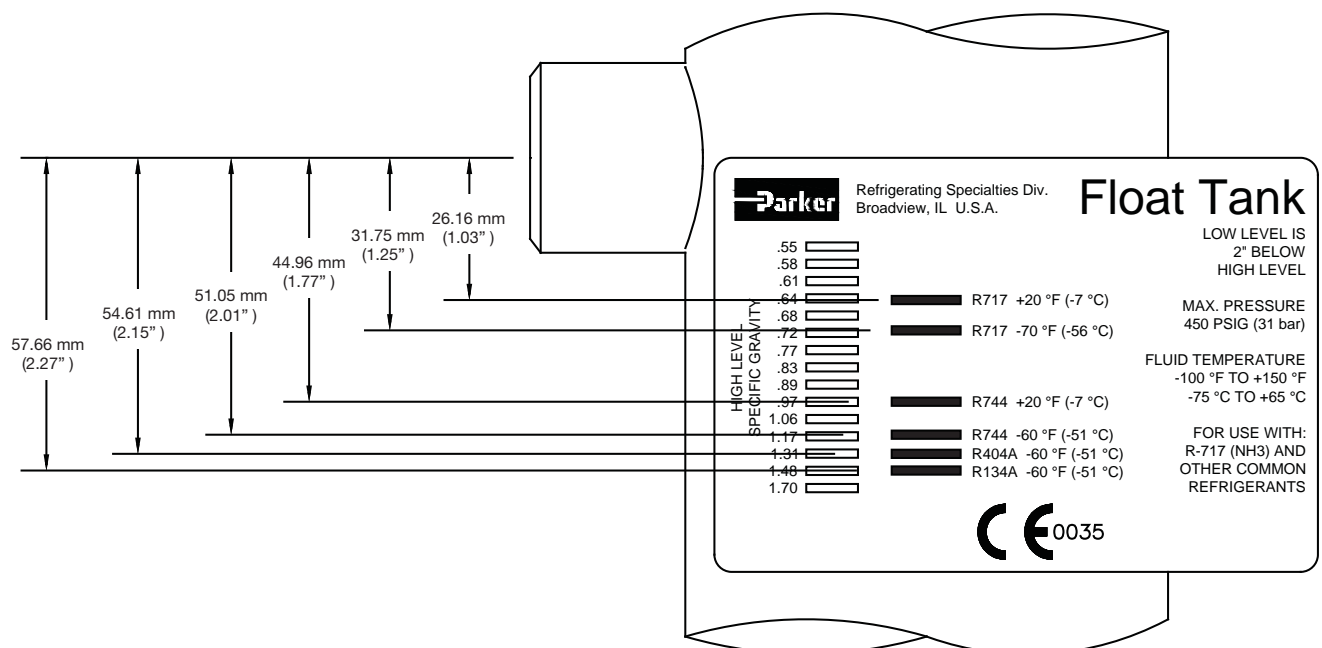

**Float Tank Nameplate and Refrigerant Level Location**

(stick, MIG, and TIG) do not create enough heat that transfers to the valve's internal parts that could be affected.

Contractors need to follow a WPS (Welding Procedure Specification) for all welding. The procedure must be qualified and welder doing the weld qualified to perform that procedure. For welding the stainless steel 304L body to carbon steel pipe, E309L and ER309L-15, -16, or -17 filler metal is a common choice. Contractors can develop their own standards and have them qualified based on the equipment they use and the environment they may encounter.

**Note:** When welding carbon steel and stainless steel the welded joint should be painted to prevent galvanic corrosion.

Before putting LLSS switches into service, all pipe connections should be tested for leaks at pressure levels called for in appropriate codes.

**Mounting Installation**

The refrigerant float switch must always be mounted in a vertical position. The side of the float chamber can be used as a leveling surface and, with the use of a simple level, proper position can be obtained.

Where the refrigerant float switch is mounted directly to the vessel (rather than on a float switch column), we recommend the installation of a hand globe valve in each of the piping connections to the float chamber. While not strictly necessary, these valves do provide access to the float chamber for cleaning or servicing without pumping out the vessel.

When installed in the horizontal pipe connections, it is recommended that the hand valves be positioned on their sides (with the stem horizontal) to avoid liquid trapping as explained earlier.

For multiple float switch installation, where the float switches are mounted on a float switch column (sometimes called balance leg or gas bypass leg), and where it would be inconvenient



Refrigerating Specialties Div.  
Broadview, IL U.S.A.

## LLSS Switch

10 A 120 VAC  
10 A 240 VAC  
1/2 A 125 VDC

AMBIENT TEMP:  
-50 °F TO +120 °F  
-45 °C TO +50 °C

FOR USE WITH:  
R-717 (NH3) AND  
OTHER COMMON  
REFRIGERANTS

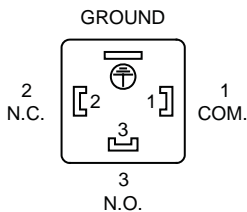

GROUND

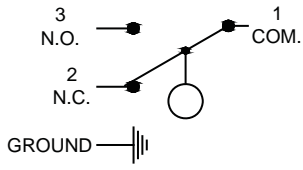

1 COM.  
2 N.C.  
3 N.O.



3 N.O.  
2 N.C.  
1 COM.  
GROUND

**Float Switch Nameplate (DIN Switch Label Shown)**

and costly to install separate hand valves on each float switch, we recommend an upper and lower hand angle valve to be installed on the switch column. This will provide access to the float chambers without pumping out the system or the vessel. We recommend a 100mm (4") pipe to be used for the switch column.

It is important to remember that, on any type of float ball application, precaution must be taken, or at least considered, to keep the liquid in the float chamber as quiet as possible. Attention to this condition will assure a proper response of the float switch to the rise and fall of the liquid level in the vessel being controlled.

In low temperature systems, where the vessel and float switches are located in a non-refrigerated room, it is quite important that the gas equalizing piping connection on the top of the float chamber be generously sized in an effort to continuously release any gas which is formed, and to prevent a depression of the liquid level in the float chamber due to a slight pressure build-up on top of the liquid.

In addition, when installed in non-refrigerated rooms, both the liquid and gas equalizing lines and float chamber (as well as the main vessel) must be insulated to minimize the "boiling" action and provide a quiet liquid level for the float ball.

**Note:** For a second side connection

weld a T-connection to the bottom tank fitting as shown in the LLSS external dimensions diagram.

**DIN Connector Electrical Installation**

The DIN connector is PED, CE and IP 65 certified.

The internal switch contact ratings are:

- 120 VAC, 10 Amps
- 240 VAC, 10 Amps
- 125 VDC, 1/2 Amps

In order to connect the wires to the DIN connector the terminal must be gently pried with a small phillips screw driver or flat blade.

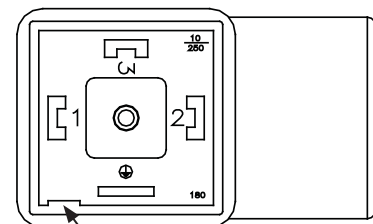

Pry here using a small flat head screw driver to remove.

**DIN Connector Face View**

Strip insulation 1/8" from end and attach wires to screws using the color codes shown in the DIN connector terminal table.

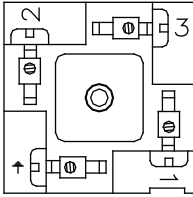

Terminal	Wire Color	Type
1	Gray	COM
2	Red	NC
3	Black	NO
G	Green	Ground

#### DIN Connector Terminal Table

#### Leaded Switch Electrical Installation

The internal switch contact ratings are:

- 120 VAC, 10 Amps
- 240 VAC, 10 Amps
- 125 VDC, 1/2 Amps

The wiring diagram, ambient temperature rating, and wiring for the leaded switch are the same as shown in the DIN nameplate diagram and DIN connector terminal table.

#### Float Switch Actuator

The tamper-proof construction of the R/S Refrigerant Float Switch necessitates an external means of actuating the switch since manual contact is not possible. When operation of the switch is desired without changing the liquid level (or to check electrical circuitry before the system is charged). The housing can be slapped with open hand to cause momentary actuation.

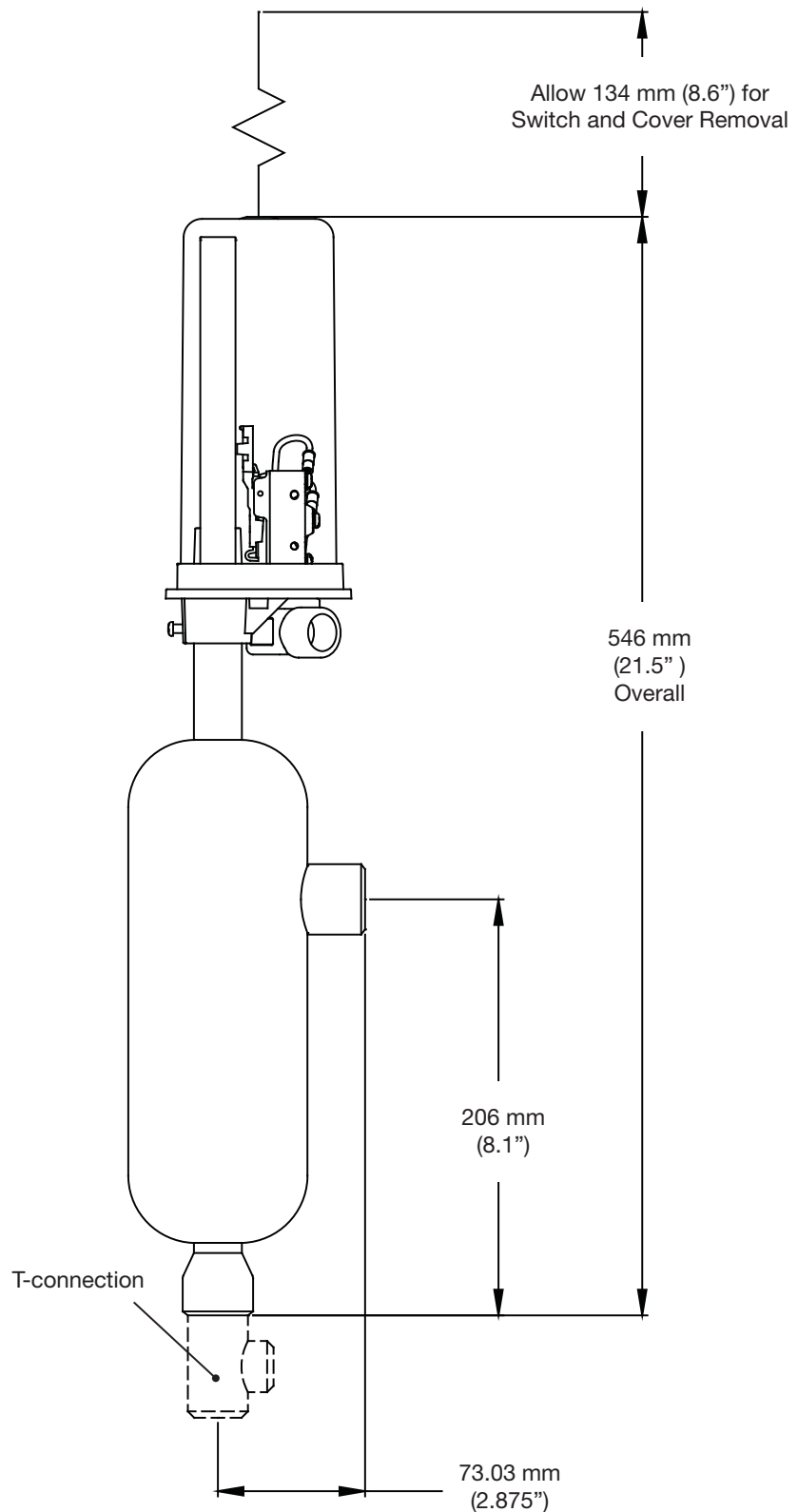

#### LLSS External Dimensions

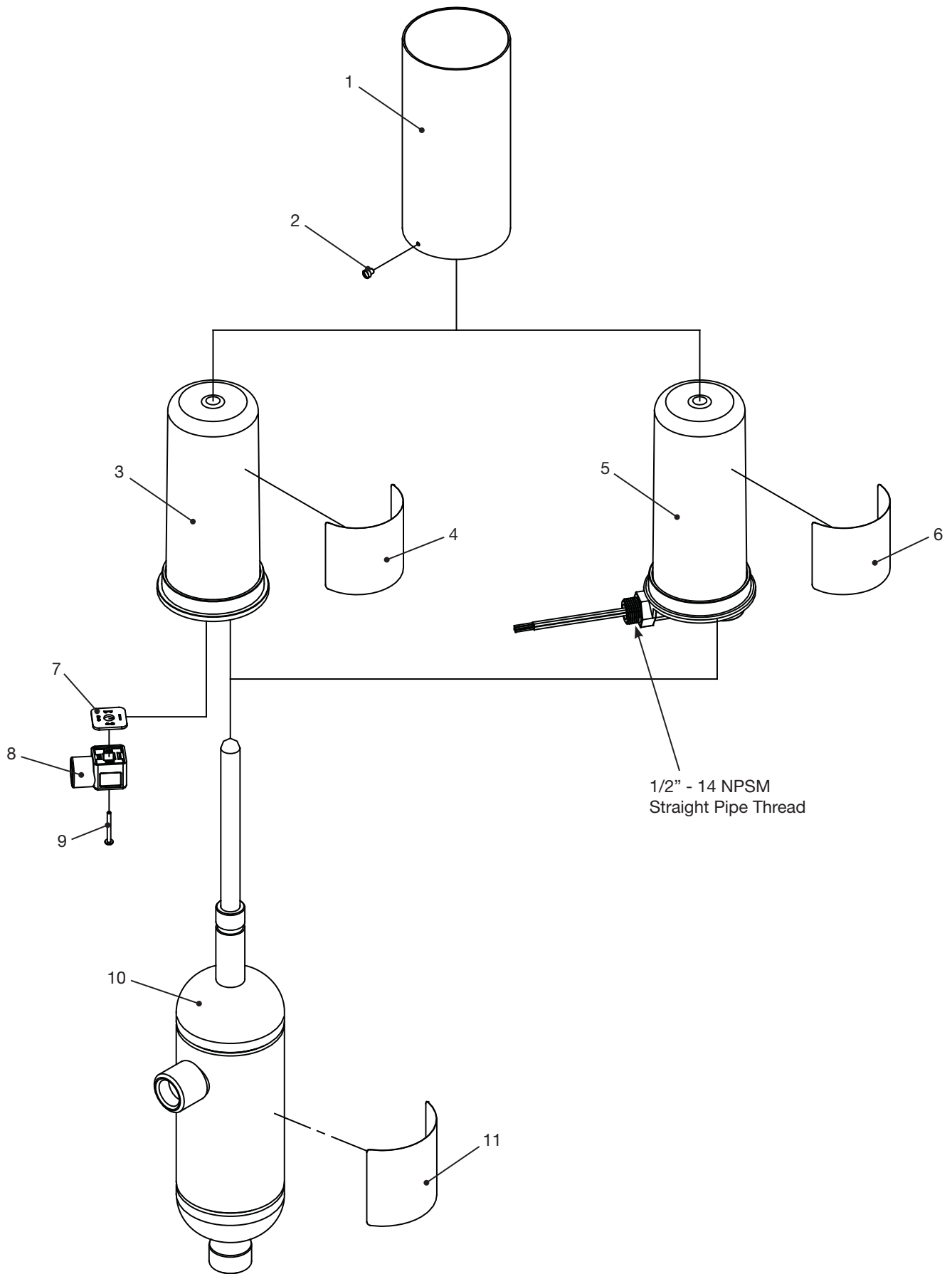

LLSS Exploded View

Item	Description	Material	Qty
1	Cover, Switch	6061-T6 Aluminum	1
2	Screw, 8-32 x 0.188"	S.S.	1
3	DIN, Switch Assembly	Molded, UV Resistant Plastic	
4	Label, DIN Switch Assembly	Metalized Polyester	1
5	Leaded, Switch Assembly	Molded, UV Resistant Plastic	1
6	Label, Leaded Switch Assembly	Metalized Polyester	1
7	Connector Seal	EDPM	1
8	DIN Connector	GDM 3012J	1
9	Screw, M3 X 0.5 Dia. X 1.115"	S.S.	1
10	Chamber, Float Tank Assembly	304L S.S.	1
11	Label, Float Tank Assembly	Metalized Polyester	1

### Float Switch Parts List

Item	Kit Description	Kit Number
1 - 2	Cover, Switch	208642
3 - 4	DIN, Switch Assembly - CE Certified	208644
5 - 6	Leaded, Switch Assembly - No Certification	208874
5 - 6	Leaded, Switch Assembly - UL Listed	209187
7 - 9	DIN Connector	208645

### Float Switch Parts Kit

#### Service Pointer

##### 1. Replacement of Switch

###### Assembly:

The Float Switch Assembly can be replaced without pumping down the float chamber. It is necessary only to disconnect the DIN at the float switch, loosen the base set screw and slide the Switch Assembly up from the Float Rod Enclosing Tube. The new Switch Assembly can then be replaced in a similar manner.

##### 2. Failure to Open or Close:

Before replacing the assembly, as described in paragraph No. 1 above, external wiring should be checked to be sure that the trouble is not somewhere other than the float switch. If the wiring is found to be in good condition, the connector can be unplugged and the terminals on the bottom of the switch can be checked for continuity with tester. The terminals are numbered the same as the DIN connector.

##### 3. Switch Current Limitations:

The electrical capacities of the switch are listed on page 4. Continual switching of overloaded contacts will, of course, eventually burn or pit them to a point where they will no longer perform their function. Gross overloading can weld the contacts together so that they will not open. Errors in field wiring which place a dead short across the contacts will cause the switch to fail. Good wiring practice will dictate using a properly sized fuse in the control circuit to protect the wiring as well as added protection for the switch.

#### Caution

Before doing any service work, always be sure to disconnect the power to the switch assembly.

---

**Safe Operation (See Bulletin RSBCV)**

People doing any work on a refrigeration system must be qualified and completely familiar with the system and the Refrigerating Specialties Division valves involved, or all other precautions will be meaningless. This includes reading and understanding pertinent Refrigerating Specialties Division Product Bulletins and Safety Bulletin RSB prior to installation or servicing work.

Where cold refrigerant liquid lines are used, it is necessary that certain precautions be taken to avoid damage which could result from liquid expansion. Temperature increase in a piping section full of solid liquid will cause high pressure due to the expanding liquid which can possibly rupture a gasket, pipe or valve. All hand valves isolating such sections should be marked, warning against accidental closing, and must not be closed until the liquid is removed. Check valves must never be installed upstream of solenoid valves, or regulators with electric shut-off, nor should hand valves upstream of solenoid valves or downstream of check valves be closed until the liquid has been removed.

It is advisable to properly install relief devices in any section where liquid expansion could take place. Avoid all piping or control arrangements which might produce thermal or pressure shock.

For the protection of people and products, all refrigerant must be removed from the section to be worked on before a valve, strainer, or other device is opened or removed. Flanges with ODS connections are not suitable for ammonia service.

**Warranty**

All Refrigerating Specialties products are under warranty against defects in workmanship and materials for a period of one year from date of shipment from factory. This warranty is in force only when products are properly installed, field assembled, maintained, and operated in use and service as specifically stated in Refrigerating Specialties Catalogs or Bulletins for normal refrigeration applications, unless otherwise approved in writing by the Refrigerating Specialties Division. Defective products, or parts thereof returned to the factory with transportation charges prepaid and found to be

defective by factory inspection, will be replaced or repaired at Refrigerating Specialties option, free of charge, F.O.B. factory. Warranty does not cover products which have been altered, or repaired in the field, damaged in transit, or have suffered accidents, misuse, or abuse. Products disabled by dirt or other foreign substances will not be considered defective.

The express warranty set forth above constitutes the only warranty applicable to Refrigerating Specialties products, and is in lieu of all other warranties, expressed or implied, written including any warranty of merchantability, or fitness for a particular purpose. In no event is Refrigerating Specialties responsible for any consequential damages of any nature whatsoever. No employee, agent, dealer or other person is authorized to give any warranties on behalf of Refrigerating Specialties, nor to assume, for Refrigerating Specialties, any other liability in connection with any of its products.



**ISO 9001 CERTIFIED**