

T2-05

Micro Diaphragm Pumps (air/gas)

Up to 800 mLPM Free Flow

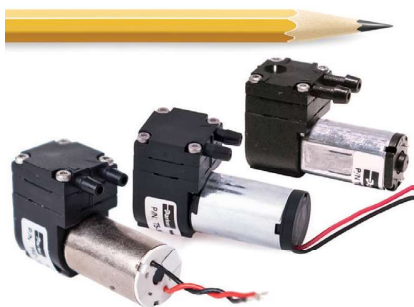

Parker's T2-05 13.5 mm wide micro diaphragm pump is designed to fit where other pumps cannot due to its small, compact package size. The T2-05 flow path is optimized to deliver high flow with high efficiency resulting in extended battery life. The pump's low power, small size, and light weight play a critical role in portable gas detection and medical applications. The T2-05 pump HE and LI pump models enable intrinsic safety capabilities for sampling of hazardous gases, typical of industrial and mining operations. The T2-05 IC pump is designed for compact and wearable medical devices that require less than 1500 hours of pump life. The T2-05 VBIC model is ideal for vacuum only medical applications that benefit from improved sound quality, such as wound therapy.

Markets

- Safety
- Patient Therapy
- Patient Monitoring

Applications

- Portable Gas Detection
- Gas Sampling
- Medical Instruments
- Trace Detection
- Sidestream CO₂
- Negative Pressure Wound Therapy

Features

- The valve design has been optimized to provide the highest flow rates available with the lowest current draw, allowing for longer battery life and smaller instrument size.
- The T2-05 model pump life ranges up to 10,000 rated hours depending on motor (HE, LI and IC) options
- The pump fits into the extremely tight spaces demanded of today's handheld instruments, such as portable gas detectors and portable negative pressure wound therapy devices for patient mobility. The lightweight design minimizes instrument weight.
- RoHS compliant. 

Product Specifications*

Physical Properties

Operating Environment¹:
-4 to 122°F (-20 to 50°C)
Storage Environment:
-4 to 122°F (-20 to 50°C)
Media:
Air, Argon, Helium, Nitrogen, Oxygen, and other non-reacting gases
Humidity:
Most non-condensing gases 5-95% Relative Humidity
Noise Level²:
As low as 45dB
Pump Assembly Rated Life³:
Coreless Motor-Pump (HE): Up to 10,000 hours Coreless Motor-Pump (LI): Up to 6,000 hours PMDC Iron Core-Pump (IC): Up to 1,500 hours
Weight:
0.5 oz (14 g) HE and LI 0.4 oz (11 g) IC

Electrical

Motor Type (DC):
High Efficiency Coreless Brush (HE) Low Inductance Coreless Brush (LI) PMDC Iron Core Brush (IC)
Nominal Motor Voltages (DC)⁴:
3.3 VDC
Max Power at Nominal Voltage:
0.36 Watts
Electrical Termination:
HE: Wire Leads LI: Wire Leads IC: Solder Tabs or Wire Leads
Current Range⁵:
34 - 105 mA
Inductance⁶:
HE: 0.28 mH maximum @ 1kHz/50mV LI: 0.05 mH maximum @ 1kHz/50mV IC: 4.07 mH maximum @ 1kHz/50 mV

Pneumatic

Head Configuration: Single
Maximum Flow:
HE, LI: 800 smlpm, IC: 700 smlpm
Maximum Intermittent Pressure⁷:
6.2 psi (430 mbar)
Maximum Continuous Pressure:
2.0 psi (138 mbar)
Maximum Intermittent Vacuum⁷:
10.8 in Hg (274 mm Hg)
Maximum Continuous Vacuum:
4.1 in Hg (104 mm Hg)
Filtration:
40 micron recommended
Efficiency at Free Flow⁸:
LPM/Watt: 4.66 @ 1.9 VDC (P/N T5-1HE-03-1EEB) LPM/Watt: 4.08 @ 1.9 VDC (P/N T5-1LI-03-1EEB) LPM/Watt: 3.12 @ 1.9 VDC (P/N T5-1IC-03-1EEP)

Wetted Materials

Diaphragm: EPDM

Valves: EPDM

Pump Head: ABS (HE, LI), PBT (IC)

* See Appendix A for details.



Performance Specifications

T2-05 Pump Coreless Brush Motor

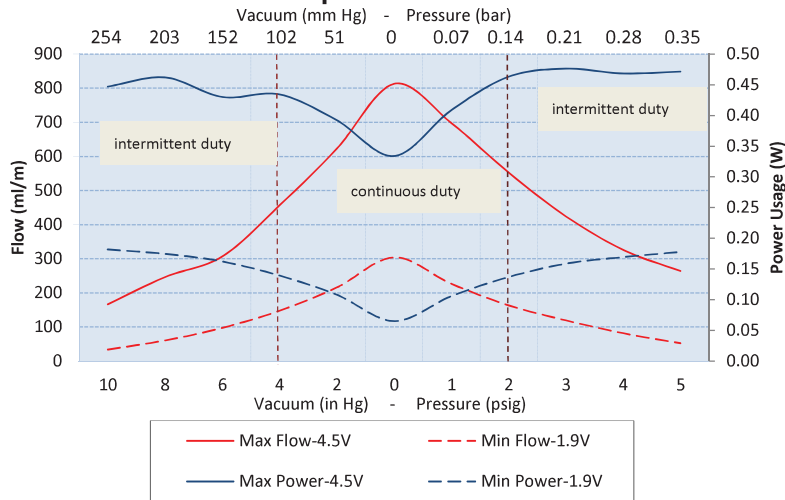

T2-05 PMDC Iron Core Brush Motor

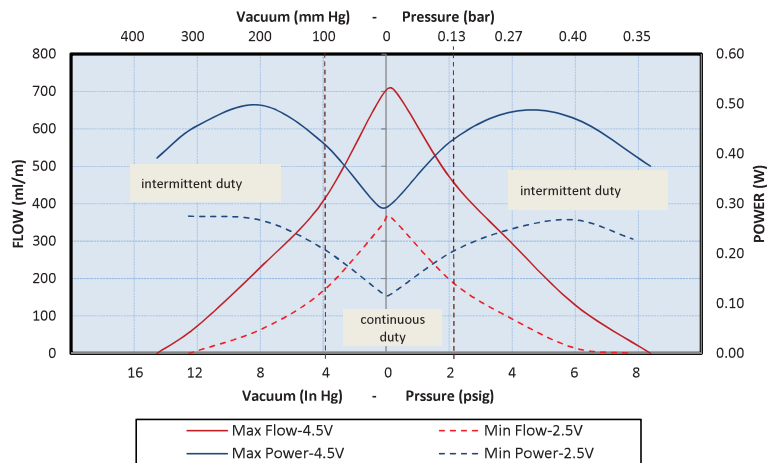

The above graphs represent examples of performance for the pumps series handling air at 800 feet [244M] above sea level at 75° F [24° C]. Performance will vary depending on barometric pressure and media temperature. Curves are representative of standard pump configurations. Pump configurations could be customized for higher or lower flows, depending on specific customer requirements.

Please contact Parker Precision Fluidics Applications Engineering for other considerations



T2-05

Micro Diaphragm Pumps (air/gas)

Sizing and Selection

T2-05 Series

Coreless Brush Motor (High Efficiency)

Coreless Brush Motor (Low Inductance)

PMDC Iron Core Motor (Iron Core)



	HE	LI	IC
Inductance ⁶	Better	Best	N/A
Efficiency at Free Flow ⁸	Best	Best	Better
Life ³	Best	Better	Good
Cost	Good	Better	Best

Mounting Guidelines:

- Parker recommends using a nylon cable tie with a length of at least 4" (100 mm).

Port Connections:

- HE & LI: 3/32" ID tubing
- IC: 1/8" ID tubing

Mechanical Integration

Dimensions

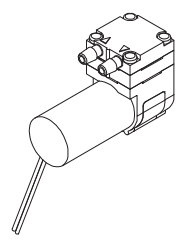
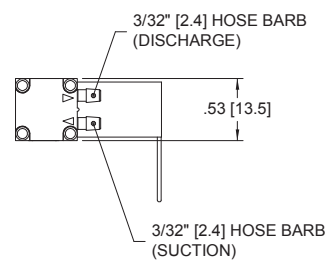

Coreless Brush/HE Version

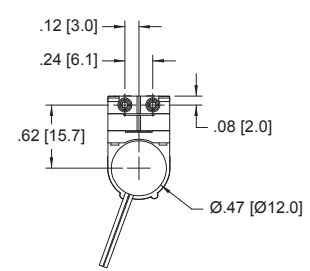
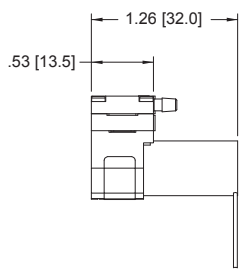

Micro Diaphragm Pumps (air/gas)

T2-05

Mechanical Integration
Dimensions

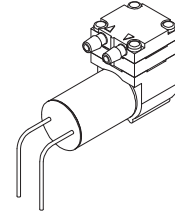
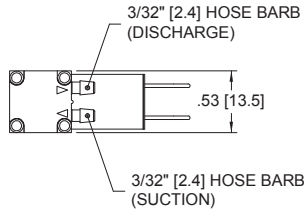

Coreless Brush/LI Version

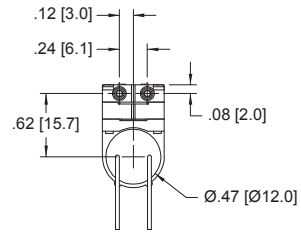
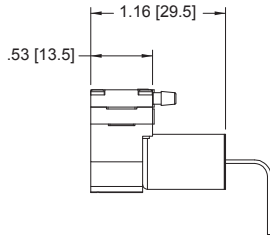

Units
IN. (mm.)

PMDC Iron Core/IC Version

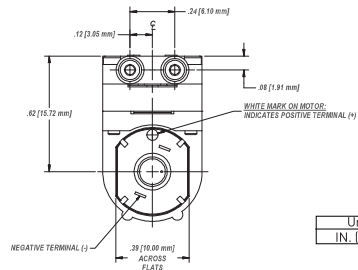
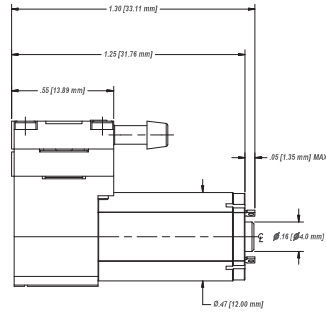
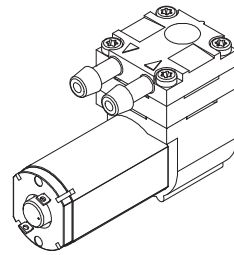
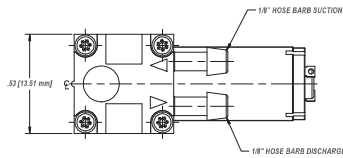

Units
IN. (mm.)

PMDC Iron Core/IC Version
Lead Wire

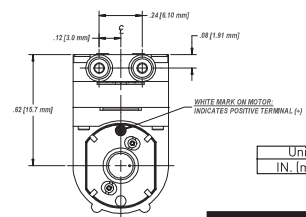
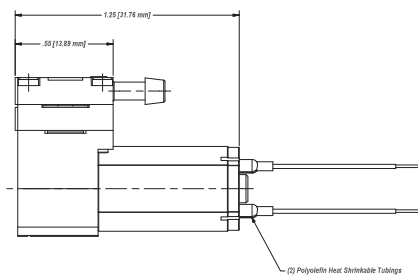
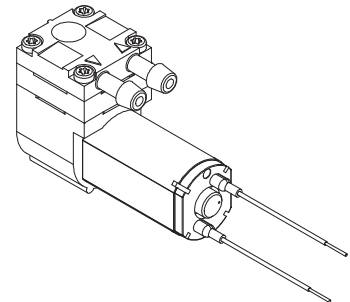
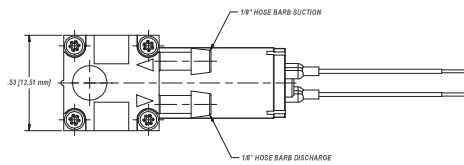

Units
IN. (mm.)



T2-05

Micro Diaphragm Pumps (air/gas)

Mechanical Integration

PMDC Iron Core/IC Version Improved Sound Configuration*

* Improved sound configuration released with IC configuration for vacuum applications. Contact factory for use with HE or LI configurations for either vacuum or pressure applications

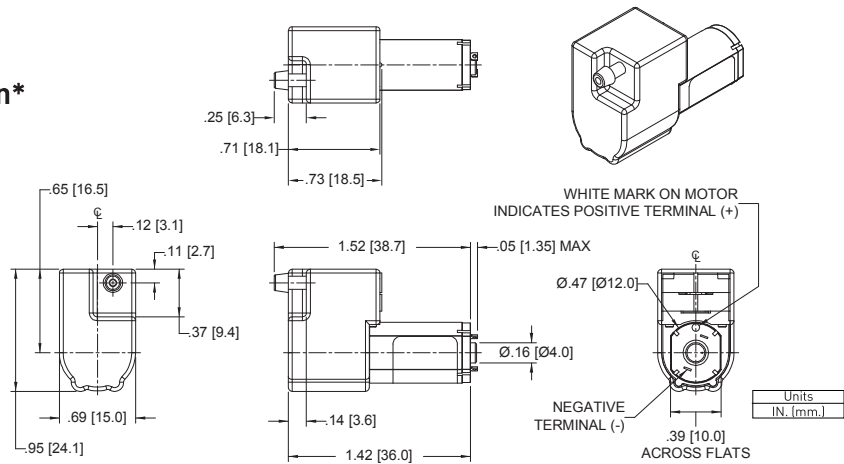

Electrical Integration and Motor Control

Coreless Brush Motor (HE, LI)

2 Wire	Red (+), Black (-)
Wire specification	28 AWG 5.7" (145 mm) PVC Wire Leads

PMDC Iron Core Brush Motor (IC)

2 Wire	Red (+), Black (-)
Wire specification	26 AWG 6.5" (165 mm) PVC Wire Leads

Key Things to Remember

Contact Parker Engineering for other connection requirements.

Pump life is highly dependent on operating conditions. It is not recommended to run the pump continuously, 100% duty cycle, at higher than 2 psig.

The pump flow and pressure can be controlled by adjusting the input voltage from zero to maximum rated voltage.

The pump is not a pressure holding device. An external check valve is recommended, if there is a pressure holding requirement.

Pump orientation does not affect performance or life.

Typical Flow Diagram

Negative Pressure Wound Therapy Diagram

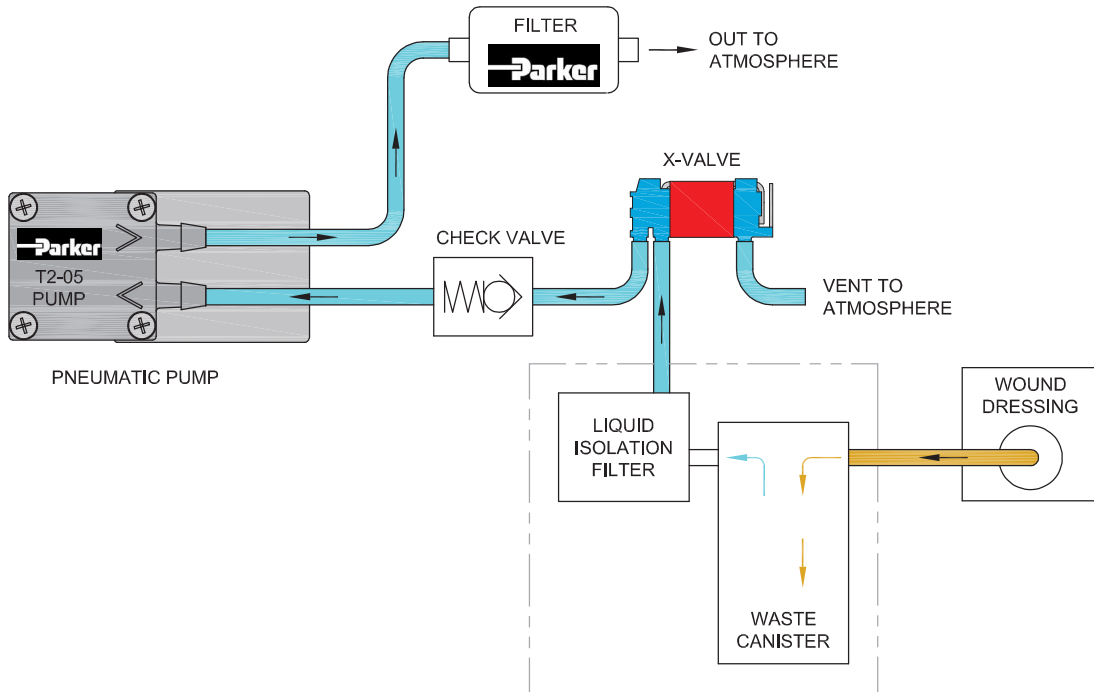

Gas Detection Diagram

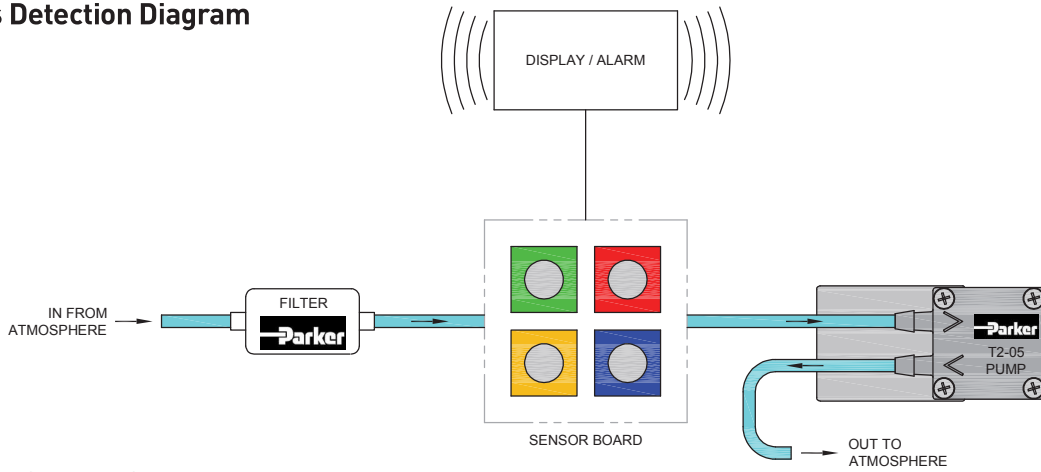

Side Stream Capnography Diagram

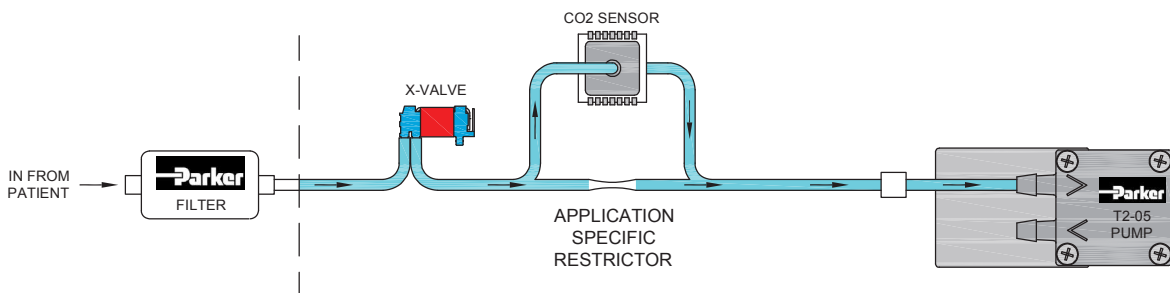

T2-05

Micro Diaphragm Pumps (air/gas)

Chemical Compatibility Chart*

Chemical	Chemical Compatibility of Wetted Path Materials		
	EPDM	ABS	PBT
Air	1	1	1
Ozone (1000 ppm)	4	2	1
Oxygen	1	1	1
Ethylene (Ethene)	4	1	1
Acetylene	1	2	2
Propane	4	2	2
Methane	4	4	2
Nitrogen	1	1	1
Carbon Dioxide	2	2	1
Halothane (Up to 5%)	4	1	1

Compatibility Legend

- EXCELLENT**
Minimal or no effect
- GOOD**
Possible swelling and/or loss of physical properties
- DOUBTFUL**
Moderate or severe swelling and loss of physical properties
- NOT RECOMMENDED**
Severe effect and should not be considered

Note: Consult factory for other gases.

*The above is an Abbreviated Chemical Compatibility Chart. Please consult factory for details.

Ordering Information

Configuration	Vacuum: LPM @ Load			Free Flow	Pressure: LPM @ Load			Max		Motor Type	PCD*		Wetted Materials
	12 in Hg 305 mm Hg	8 in Hg 203 mm Hg	4 in Hg 102 mm Hg		2 psig 134 mbar	4 psig 276 mbar	6 psig 414 mbar	Vac in Hg	Press psig		VDC	mA	
T5-1HE-03-1EEB		0.2	0.5	0.8	0.6	0.3		10.8	6.2	Coreless Brush	4.5	438	EPDM
T5-1LI-03-1EEB-1		0.2	0.5	0.8	0.6	0.3		10.8	6.2	Coreless Brush	4.5	438	EPDM
T5-1IC-03-1EEP		0.2	0.5	0.7	0.5	0.3		10.0	6.2	PMDC	4.5	240	EPDM
T5-VBIC-03-1EEP		0.2	0.5	0.7				10.0		PMDC	4.5	240	EPDM
T5-1ICW-03-1EEP		0.2	0.5	0.7	0.5	0.3		10.0	6.2	PMDC	4.5	240	EPDM

*PCD: Peak Current Draw

The T5-VBIC-03-1EEP is a T2-05-IC Reduced Sound pump that uses a proprietary design to reduce noise and it is a recommended option in applications where sound quality is also a critical customer need.

T2-05-LI and HE model Sound Improvement options are also available, contact applications for more details. Applications Engineering can assist with sound quality evaluations given the complex relationship between system components and operational requirements of the customer's specific application.

Ordering Information

Please refer to sizing and selection chart for identifying which one will fit your application

Please click on the Order On-line button below (or go to www.parker.com/precisionfluidics/t5) to configure your T2-05 Micro Diaphragm Pump.

Serviceable – PPF products are designed for use through the rated life and Parker does not sell replacement parts, nor is it recommended to service these in the field

Note: In addition to Parker's innovative and flexible pump designs, we offer applications engineering expertise to our customers in order to configure and recommend the optimal pump for the application. Contact Parker Applications Engineering to discuss and configure alternate pump configurations to meet your specific application requirements. Providing information on the following requirements will assist us in developing an optimal solution for your application:

- Noise
- Operating Pressure / Vacuum
- Power Consumption
- Life Requirement
- Size
- Motor Control
- Media
- Voltage



Parker Hannifin Precision Fluidics Division reserves the right to make changes. Drawings are for reference only.

Appendix A

All performance data is typical based on standard conditions: 70°F and 14.7 psia (21°C and 1 bar).

1. Duty Dependent. For operation above 122°F (50°C) consult factory
2. Noise is dependent on the configuration and operation of the pump in the application. Parker has the ability to tailor the pump configuration when noise is a critical criterion in the effort to meet the performance requirements of the application. Noise level is tested to Parker protocol P-105.
3. Life rating can vary depending on application and operating conditions.
4. Custom motor options available. Custom motors may require a significant application potential. The standard motors can be configured with a special winding to meet a particular operation point at a specified voltage
5. Current range is dependent on motor type, voltage, pressure/vacuum and flow requirement. Lower levels possible depending on application.
6. Inductance is an indicator of induced voltage with change in current and it is a key parameter to enable customers' low energy intrinsic safety systems
7. Maximum intermittent pressure/vacuum data is a pump capability guideline for applications that go beyond the maximum continuous levels for short periods of time. Please consult customer specific requirements with the factory or Applications Engineering.
8. Pump efficiency is a measure of the flow rate generated per unit of power consumed. Efficiency may change dependent on application and operating condition at free flow.