

# Compressed Air Dryers

## Balston Compressed Air Dryers

Balston offers both membrane and PSA technology. Balston Membrane Air Dryers combine superior coalescing technology with a proven, innovative membrane system to supply clean, dry compressed air with dewpoints as low as  $-40^{\circ}\text{F}$  ( $-40^{\circ}\text{C}$ ).

Balston PSA Compressed Air Dryers will reduce the dewpoint of compressed air to  $-100^{\circ}\text{F}$  ( $-73^{\circ}\text{C}$ ). Each dryer is delivered complete and ready for easy installation.



## Product Features:

- Unattended 24 hour operation
- Compact
- Membrane and PSA technologies available
- Silent operation
- No desiccant to change
- Easy to install and operate

Moisture Sensitive Point of Use Areas



Main Ring Applications



Process and Production Equipment



# Compressed Air Dryers

## Membrane Air Dryers



Balston  
Membrane Air Dryers

### State-of-the-Art Membrane Technology

Water vapor from the compressed air supply passes through the hollow fibers of the membrane. At the same time, a small portion of the dry air product is redirected along the length of the fibers to sweep out the water vapor laden air which has permeated the membrane. The moisture-laden sweep gas is then vented to the atmosphere, and clean, dry air is supplied to the application. The drying power of the membrane is controlled by varying the compressed air flow rate and pressure. The Balston Membrane Air Dryer is designed to operate continuously, 24 hours per day, 7 days per week. The only maintenance required is changing the prefilter cartridge twice a year. This semi-annual maintenance takes approximately 5 minutes.

**Offer a reliable, efficient, and economical alternative to pressure swing and refrigerant dryer technologies**

**Require no electricity thus lowering operating costs**

**Dewpoints as low as -40°F (-40°C) prevent freeze-ups**

**Explosion proof**

**Silent operation**

**No desiccant to change**

### Membrane Air Dryers

Balston Membrane Air Dryers combine a superior coalescing technology with a proven, innovative membrane system to supply clean, dry compressed air with dewpoints as low as -40°F (-40°C). The Membrane Air Dryers are engineered for easy installation, operation, and long term reliability. The dryers incorporate high efficiency coalescing filtration and the highest efficiency membrane available to provide low cost operation and minimal maintenance.

#### Applications

Low dewpoint instrument air	Prevention of freeze-ups
Pneumatic equipment	Dry air for hazardous areas
Pressurizing electronic cabinets	General laboratory air supply
Analytical instrumentation	Protect electrical panel components from moisture damage

**- "We have not had one shutdown due to freeze-ups since the Balston Membrane Dryer was installed."**

Peter Vogt  
International Filler Corp.

# Compressed Air Dryers

## Membrane Air Dryers

### Membrane Air Dryer - Principle of Operation

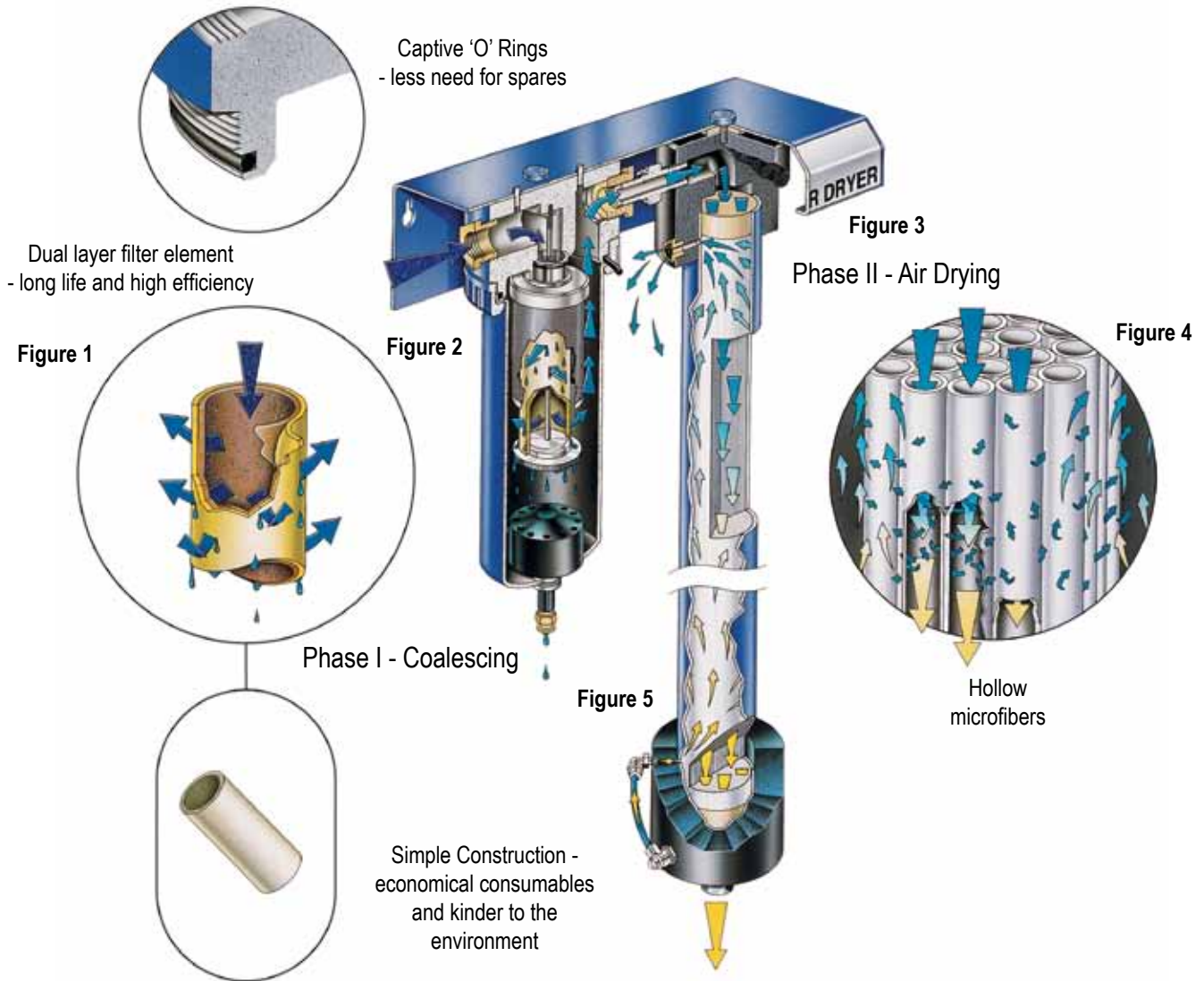

#### Phase I - Coalescing Filtration

Prior to entering the membrane drying module, the compressed air passes through a high efficiency coalescing filter to remove oil and water droplets and particulate contamination with an efficiency of 99.99% at 0.01 micron. The liquids removed by the filter cartridge continuously drip from the filter cartridge into the bottom of the housing, where they are automatically emptied by an auto-drain assembly (see Fig. 1 and Fig. 2). The air leaving the prefilter, therefore, is laden only with water vapor, which will be removed in the membrane module.

#### Phase II - Drying

The water vapor in the compressed air is removed by the principle of selective permeation through a membrane (see Fig. 3). The membrane module consists of bundles of hollow membrane fibers (see Fig. 4), each permeable only to water vapor. As the compressed air passes through the center of these fibers, water vapor permeates through the walls of the fiber, and dry air exits from the other end of the fiber. A small portion of the dry air (regeneration flow) is redirected along the length of the membrane fiber to carry away the moisture-laden air which surrounds the membrane fibers. The remainder of the dry air is piped to the application.

# Compressed Air Dryers

## Membrane Air Dryers for -40°F Dewpoint



Model 76-01



Model 76-02



Model 76-10



Model 76-20



Model 76-40

Flow Rates					
Outlet Flow (SCFM) at Indicated Operating Pressure (psig) for -40°F (-40°C) Atmospheric Dewpoint					
Pressure Dewpoint	60 psig -40°F(-40°C)	80 psig -40°F(-40°C)	100 psig -40°F(-40°C)	120 psig -40°F(-40°C)	140 psig -40°F(-40°C)
Model 76-01	.3	.6	1	1.3	1.7
Model 76-02	.6	1	2	2.4	3.4
Model 76-10	3.0	5	10	13	17
Model 76-20	6.0	10	20	26	34
Model 76-40	12.0	20	40	52	68

Membrane Module Regeneration Flow					
Regeneration Flow (SCFM) at Indicated Operating Pressure (psig) and all dewpoints					
Pressure Dewpoint	60 psig	80 psig	100 psig	120 psig	140 psig
Model 76-01	.2	.2	.3	.3	.3
Model 76-02	.34	.4	.5	.6	.7
Model 76-10	1.7	2.1	2.5	3	3.3
Model 76-20	3.4	4.2	5	6	6.6
Model 76-40	6.8	8.4	10	12	14

# Compressed Air Dryers

## Membrane Air Dryers for -40°F Dewpoint

Principal Specifications					
Model	76-01	76-02	76-10	76-20	76-40
Max. Flow Rate At -40°F (-40°C) Dewpoint (1)	1 SCFM	2 SCFM	10 SCFM	20 SCFM	40 SCFM
Min/Max Inlet Air Temp. (2)	40°F/120°F (4°C/49°C)	→			
Ambient Temp. Range	40°F - 120°F (4°C - 49°C)	→			
Min/Max Inlet Pressure	60 psig/150 psig	→			
Compressed Air Requirement	Total Air Consumption: Regeneration Flow + Outlet Flow Requirements (see tables on pg.166)				
Max. Pressure Drop (3)	5 psid	5 psid	5 psid	5 psid	5 psid
Wall Mountable	Yes	Yes	Yes	Yes	Yes
Prefilter (included) (4)	Yes	Yes	Yes	Yes	Yes
Inlet/Outlet Port Size	1/4" NPT (female)	1/4" NPT (female)	1/2" NPT (female)	1" NPT (female)	1 1/2" NPT (female)/ 3/4" NPT (female)
Electrical Requirements	None	None	None	None	None
Dimensions	6"W x 22"H x 5"D (15cm x 58cm x 13cm)	6"W x 23"H x 5"D (15cm x 58cm x 13cm)	6"W x 37"H x 5"D (15cm x 94cm x 13cm)	12"W x 37"H x 7"D (30cm x 94cm x 18cm)	19"W x 39"H x 8"D (48cm x 99cm x 21cm)
Shipping Weight	9 lbs. (4 kg)	10 lbs. (5 kg)	18 lbs. (9 kg)	20 lbs. (9 kg)	35 lbs. (16 kg)

**Notes:**

1 Dewpoint specified for saturated inlet air at 100°F (38°C) and 100 psig. Outlet flows will vary slightly for other inlet conditions.

2 Inlet compressed air dewpoint must not exceed the ambient air temperature.

3 5 psid at -40°F (-40°C) dewpoint operating parameters.

4 If compressed air is extremely contaminated,

a Balston Grade DX prefilter should be installed directly upstream from the membrane dryer.

Ordering Information					
For Assistance, call toll-free at 1-800-343-4048 8AM to 5PM Eastern Time					
Description	Model Number				
Balston Membrane Air Dryer	76-01	76-02	76-10	76-20	76-40
Replacement Prefilter Cartridges	100-12-BX	100-12-BX	100-18-BX	150-19-BX	200-35-BX
Optional Additional Coalescing Prefilter	2004N-1B1-DX	2004N-1B1-DX	2104N-1B1-DX	2208N-1B1-DX	2312N-1B1-DX
Replacement Filter Cartridges for Optional Prefilter	100-12-DX	100-12-DX	100-18-DX	150-19-DX	200-35-DX
Pressure Regulator (0-130 psig) 1/2" NPT Ports	72-130	72-130	72-130	-----	---



# Compressed Air Dryers

## IT Series Membrane Air Dryers for +35°F Dewpoint\*

Offer a reliable, efficient, and economical alternative to pressure swing and refrigerant dryer technologies

Require no electricity thus lowering operating costs

Produce +35°F dewpoint, ideal for critical points of use

Produce +15°F dewpoint in air systems with existing refrigerated air dryers

No moving parts

Silent operation



### Applications

Food processing and automation  
Electronics/Dry Boxes  
Coordinate Measurement Machines  
Critical Pneumatic Valves  
Protection of Pneumatic Instrumentation  
Low Dewpoint Instrument Air  
Pneumatic Equipment  
Pressurizing Electronic Cabinets  
Dry Air for Hazardous Areas

### IT Series Membrane Dryers

There are many variables that will affect the output specification of compressed air. By the time air reaches all its intended point of use, changes in pressure and temperature can contribute to potential contamination. As capital equipment tolerances become tighter and more sensitive to this contamination, maintenance costs will escalate if equipment is not adequately protected. In cases where standard air filtration is not sufficient or where the reliability, performance and operating cost of older dryer technologies is becoming more significant, a Balston Membrane Dryer provides a reliable and economical alternative.

### IT Series Point of Use Membrane Dryers

Balston Membrane Air Dryers combine superior coalescing filtration technology with a proven, innovative membrane system to supply clean, dry, +35°F dewpoint compressed air. If the house compressed air is equipped with a refrigerated dryer, the dewpoint drops to +15°F. The Balston Membrane Dryers are available in 8 different models which can deliver compressed air at flow rates up to 100 SCFM . dewpoint. The systems are engineered for easy installation, operation, and long term reliability. By incorporating high efficiency coalescing filtration and the highest efficiency membrane available, the systems provide low cost operation with the lowest minimal maintenance.

\* If the house compressed air is equipped with a refrigerated dryer, the dewpoint drops to +15°F.

# Compressed Air Dryers

## IT Series Membrane Air Dryers for +35°F Dewpoint\*



IT0010-35



IT0030-35



IT0080-35



IT0150-35



IT0250-35XX



IT0500-35XX

### Easy to Operate and Maintain

Installation consists of simply connecting a standard compressed air line to the inlet and connecting the outlet to your application. The unit is ready for trouble-free operation. This system is designed to operate 24 hours per day, 7 days per week.

Once the system is operating, it requires little monitoring. The only maintenance involves changing the coalescing prefilter cartridges periodically. The membrane module does not require any maintenance.

### Flow Rates

Model Number	IT0010-35	IT0030-35	IT0080-35	IT0150-35	IT0250-3560	IT0250-3500	IT0500-3560	IT0500-3500	IT1000-3560	IT1000-3500
Flow @ 100 psig Inlet Pressure (scfm)	1	3	8	15	25	N/A	50	N/A	100	N/A
Flow @ 101-150 psig Inlet Pressure (scfm)	1	3	8	15	N/A	25	N/A	50	N/A	100
Regeneration Flow @ 100 psig (scfm) (1)	0.25	0.5	1.5	2.7	4.5	4.5	9.0	9.0	18.0	18.0

(1) Total Air Consumption = Regeneration + Outlet Flow.

\* If the house compressed air is equipped with a refrigerated dryer, the dewpoint drops to +15°F.



# Compressed Air Dryers

## IT Series Membrane Air Dryers for +35°F Dewpoint\*

### Principal Specifications

Model Number	IT0010-35	IT0030-35	IT0080-35	IT0150-35	IT0250-3560	IT0250-3500	IT0500-3560	IT0500-3500	IT1000-3560	IT1000-3500
Min/Max Inlet Air Temp.	40°F/120°F 4°C/49°C	40°F/120°F 4°C/49°C	40°F/120°F 4°C/49°C	40°F/120°F 4°C/49°C	40°F/120°F 4°C/49°C	40°F/120°F 4°C/49°C	40°F/120°F 4°C/49°C	40°F/120°F 4°C/49°C	40°F/120°F 4°C/49°C	40°F/120°F 4°C/49°C
Min/Max Ambient Air Temp.	40°F/120°F 4°C/49°C	40°F/120°F 4°C/49°C	40°F/120°F 4°C/49°C	40°F/120°F 4°C/49°C	40°F/120°F 4°C/49°C	40°F/120°F 4°C/49°C	40°F/120°F 4°C/49°C	40°F/120°F 4°C/49°C	40°F/120°F 4°C/49°C	40°F/120°F 4°C/49°C
Min/Max Inlet Pressure	60/150 psig 4.1/10 barg	60/150 psig 4.1/10 barg	60/150 psig 4.1/10 barg	60/150 psig 4.1/10 barg	60/100 psig 4.1/6.9 barg	100/150 psig 6.9/10 barg	60/100 psig 4.1/6.9 barg	100/150 psig 6.9/10 barg	100/150 psig 6.9/10 barg	100/150 psig 6.9/10 barg
Max. Pressure Drop (1)	3 psid	3 psid	3 psid	3 psid	5 psid	5 psid	5 psid	5 psid	5 psid	5 psid
Wall Mountable	Yes	Yes	Yes	Yes	Yes	Yes	Yes	Yes	Yes	Yes
Mechanical Separator Included	F14F17B	F06F18B	F06F18B	F07F38B	F07F38B	F07F38B	F07F38B	F07F38B	F602-08WJR	F602-08WJR
Coalescing Prefilters (1)	8A02N-OB2-BX (2)	2002N-OB1-BX (2)	2002N-OB1-BX (2)	B2004N-1B1-DX B2004N-OB1-BX	2104-1B1-DX 2104-OB1-BX	2104N-1B1-DX 2104-OB1-BX	2208N-1B1-DX 2208N-OB1-BX	2208N-1B1-DX 2208N-OB1-BX	2208N-1B1-DX 2208N-OB1-BX	2208N-1B1-DX 2208N-OB1-BX
inlet Port Size	1/4" NPT	1/4" NPT	1/4" NPT	1/2" NPT	1/2" NPT	1/2" NPT	1/2" NPT	1/2" NPT	1" NPT	1" NPT
Outlet Port Size	1/4" NPT	1/4" NPT	1/4" NPT	1/2" NPT	1" NPT	1" NPT	1" NPT	1" NPT	1" NPT	1" NPT
Electrical Requirements	None	None	None	None	None	None	None	None	None	None
Dimensions (cm)	17.5"Lx8"Wx2.5"D 44.5 x 20.3 x 6.3	18.1"Lx10"Wx4"D 45.2 x 10.5 x 6.3	24"Lx11.1"Wx4"D 61 x 28.2 x 6.3	25"Lx16"Wx4.5"D 63.5 x 40.6 x 11.4	26"Lx18"Wx6"D 66 x 45.7 x 15.2	26"Lx18"Wx6"D 66 x 45.7 x 15.2	39"Lx21"Wx6"D 99 x 53.3 x 15.2	39"Dx21"Wx6"D 99 x 53.3 x 15.2	47"Dx28"Wx7"D 119 x 71 x 18	47"Dx28"Wx7"D 119 x 71 x 18
Shipping Weight	1.62 lbs (.73 kg)	6.68 lbs (3 kg)	6.68 lbs (3 kg)	14.88 lbs (6.75 kg)	24.5 lbs (11.11 kg)	24.5 lbs (11.11 kg)	36.5 lbs (16.55 kg)	36.5 lbs (16.55 kg)	52 lbs (24 kg)	52 lbs (24 kg)

Notes:

1 If compressed air is extremely contaminated, a Grade DX prefilter should be installed directly upstream of the membrane dryer.

### Ordering Information for assistance call toll free at 800-343-4048, 8AM to 5PM EST

Model Number	IT0010-35	IT0030-35	IT0080-35	IT0150-35	IT0250-3560	IT0250-3500	IT0500-3560	IT0500-3500	IT1000-3560	IT1000-3500
Replacement Prefilter Cartridges*										
Stage 1	PS403	PS702	PS702	PS802	PS802	PS802	PS802	PS802	EK602VB	EK602VB
Stage 2 **	---	---	---	5/100-12-DX	5/100-18-DX	5/100-18-DX	5/100-18-DX	5/150-19-DX	5/150-19-DX	5/150-19-DX
Stage 3	5/050-05-BX	5/100-12-BX	5/100-12-BX	5/100-12-BX	5/100-18-BX	5/100-18-BX	5/150-19-BX	5/150-19-BX	5/150-19-BX	5/150-19-BX

\* If the house compressed air is equipped with a refrigerated dryer, the dewpoint drops to +15°F.



# Compressed Air Dryers

## 5000 Series Smart Dryer Membrane Air Dryers

**Operating costs are 35 - 40% less than a refrigerant air dryer\***

**No electricity required**

**State-of-the-art membrane technology**

**Guaranteed 35°F dewpoint - 13% dryer than refrigerant dryers**

**Guaranteed 15°F in air systems equipped with a refrigerant air dryer**

**Durable - will hold up to the dirtiest compressed air system**

**No requirement for costly maintenance contracts**

**Output capacities to 200 scfm \*\***

**Complete system with prefilters, autodrain, and pressure indicators**



Model SMRT 5600

### The Only Way To Dry Compressed Air!

Now, there is only one sensible way to dry compressed air! High efficiency, durable membrane technology is quickly becoming the standard for drying compressed air. Parker Hannifin is leading the way with membrane technology that consumes the least amount of compressed air for drying.

The SMART Dryer™ utilizes sophisticated technology to monitor system parameters and automatically adjusts the regenerative sweep flow as required. The variable sweep system results in significant energy savings and low operating costs.

The SMART Dryer™ technology offers another advantage over refrigerant air drying technology as it does not produce condensate. An average 25 HP compressor system can produce up to 1,800 gallons of oily condensate per year! The refrigerant dryer condenses it into an oily/water emulsion which has to be disposed of at a high cost to you! The Balston® Membrane Air Dryer is designed to operate continuously, 24 hours a day, 7 days a week. The only maintenance required is changing the prefilter cartridges twice a year, which take approximately 5 minutes and requires no tools!

\*Non-cycling refrigerant air dryer

\*\* Consult Factory for higher flow rates

Applications	Benefits
<ul style="list-style-type: none"> <li>General Compressed Air Mainlines</li> <li>Process Controls</li> <li>HVAC Systems</li> <li>Instrument Cabinets</li> <li>CNC/CMM Machinery</li> <li>Fire and Sprinkler Systems</li> <li>Pneumatic Controls</li> <li>Dry Air for Hazardous Areas</li> <li>Chemical Blanketing and Packaging</li> <li>Electronics/Dry Boxes</li> <li>Laser Optics</li> <li>Spray Painting</li> <li>Bag House Controls</li> </ul>	<ul style="list-style-type: none"> <li>Easy to install - no electrician required to install or maintain system</li> <li>No refrigerants or freons - environmentally friendly</li> <li>Complete system with prefilters, auto drains, and pressure gauges</li> <li>Compact size</li> </ul>



# Compressed Air Dryers

## 5000 Series Smart Dryer Membrane Air Dryers

### Why buy a Balston SMART Dryer™ instead of a cycling refrigerant air dryer?

The Balston SMART Dryer will save YOU money and offer better performance!

All Balston SMART Dryers require no electricity.

All air dryers are sized based on the maximum capacity output of a compressed air system with inlet conditions assumed to be 100°F inlet temperature, 100 psig inlet pressure and 100°F ambient temperature. In the majority of installations, it is unlikely air dryers will be required to operate under these extreme conditions. Most importantly, the majority of compressed air systems are not operating at the maximum output capacity.

Refrigerant and desiccant air dryers, sized to meet these operating conditions are designed to run continuously regardless of the system's demands, when in fact the actual system conditions are far less.

The result is significant operating costs in wasted energy and wear and tear on refrigerant compressors, cooling systems, drains and other componentry.

In a typical manufacturing plant operating one 8 hour shift with a 100 SCFM compressor system running at 75% capacity (on average over the 8 hour shift), a typical non-cycling refrigerant air dryer would cost \$716 in just electrical costs alone, compared to the Balston SMART Dryer with only \$436 in electrical costs. If you factor in the annual maintenance costs of \$600 for a non-cycling refrigerant dryer compared to \$130 for the Balston SMART Dryer, there is a total annual savings of over \$750.

Recently, refrigerant manufacturers have responded to this issue by developing a cycling air dryer which cools a cold storage heat sink reservoir. Once the reservoir is cooled to the minimum temperature the compressor (refrigerant) is shut off. The compressor cycles back on when the temperature of the storage reservoir reaches a preset upper limit. This reduces the total energy consumption of the dryer however it could produce significant variations in output dewpoints.

The Balston SMART Dryer does not require refrigerant, compressors, cooling systems or other componentry that carries high operating costs (energy) and maintenance costs. The Balston SMART Dryer utilizes sophisticated technology to monitor the system parameters and automatically adjusts the regenerative sweep flow as required. The variable sweep system results in significant energy savings and low operating costs with no fluctuation in output dewpoints.

In a typical manufacturing plant operating an 8 hour shift with 100 SCFM compressor system running at 75%

capacity (on average over the 8 hour shift), a typical cycling refrigerant air dryer would cost \$454.00 in electrical costs alone, compared to the Balston SMART Dryer with only \$436.00 in electrical costs. If you factor in the annual maintenance cost of \$800 for a cycling refrigerant dryer compared to \$130.00 for the Balston SMART Dryer, there is a total annual savings of over \$685.00

Additionally, there are no moving parts, no freons that need recharging, no compressors to be serviced and no cooling coils to be cored and cleaned.

Most importantly, the Balston SMART Dryer is producing a constant 35°F dewpoint which is 13% dryer than a cycling refrigerant air dryer (ppm weight in air).

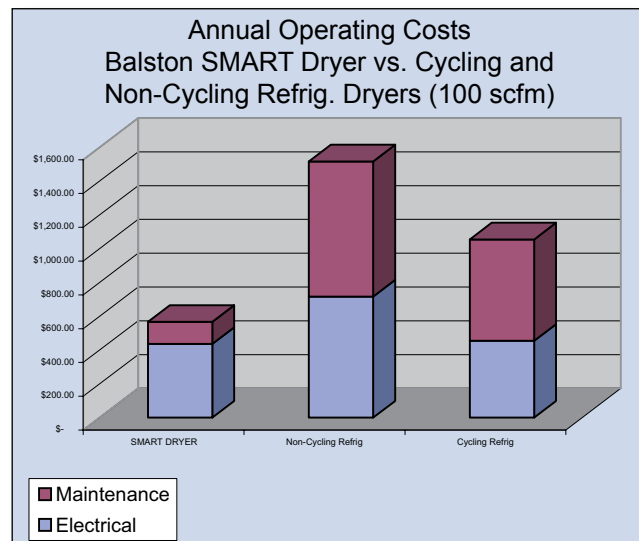

### Here's What Our Customers Say

"Our compressed air system is now completely dry and clean at a very reasonable cost. And we gain at least three hours of production time each week by not having to shut down to clean rusted valves..."

Wayne Etchells, Vice President  
Melton Corporation, Cranston, R.I.

"This new type of membrane dryer was just what we needed to eliminate problems with water building up in compressed air lines...Since the day we installed it, we haven't had a single problem with rust. The time and money we save by not having to repair spindles and air motors pays for the cost of the dryer every few months."

John Napier, Maintenance Engineer  
King Machine, Akron, OH

# Compressed Air Dryers

## 5000 Series Smart Dryer Membrane Air Dryers

Model SMRT5100  
Front View

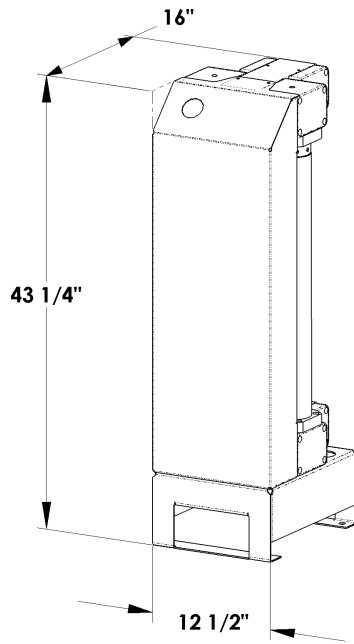

Model SMRT5200  
Front View

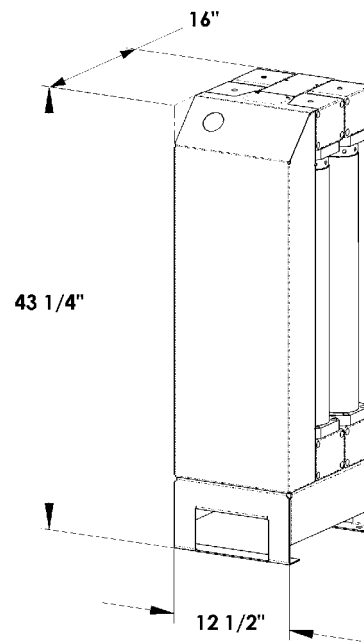

### Principal Specifications

Membrane Air Dryers		
Model Number	SMRT5100	SMRT5200
Max Flow Rate @35°F dewpoint	100 SCFM	200 SCFM
Dewpoint (1)	35°F (2°C) / 15°F (-9°C)	35°F (2°C) / 15°F (-9°C)
Min/Max Inlet Air Temp.	40°F/120°F (4°C/49°C)	40°F/120°F (4°C/49°C)
Ambient Temp. Range	40°F/110°F (4°/43°C)	40°F/110°F (4°/43°C)
Min/Max Inlet Pressure	80 psig/150 psig (5.5 barg/10 barg)	80 psig/150 psig (5.5 barg/10 barg)
Max Dewpoint	120°F	120°F
Max Compressed Air Requirement	113 SCFM	226 SCFM
Max Pressure Drop (2)	10 psi (0.7 bar)	10 psi (0.7 bar)
Inlet/Outlet Port Size	1 1/2"NPT(male)	2"NPT(male)
Physical Dimensions (3)	12.5"w x 43.25"h x 16"d	12.5"w x 43.25"h x 16"d
Shipping Weight	175 lbs(86 kg)	250 lbs(113kg)

Notes:

- 1 35°F Dewpoint specified for saturated inlet air at 100°F(38°C) and max. flow at 100 psig. 15°F Dewpoint specified for saturated inlet air at 50°F (10°C) and max. flow at 100 psig.
- 2 Max. pressure drop measured at max flow rate @ 100 psig. Pressure drop will increase at lower feed pressures - consult factory.
- 3 Excluding coalescing prefilter assembly.

### Ordering Information For assistance call 1-800-343-4048

Model Number	SMRT5100	SMRT5200
Coalescing Prefilter Assembly	2312N-1B1-DX 2312N-1B1-BX	A15/80-DX A15/80-BX
Replacement Prefilter Cartridges (every 6 months)	200-35-DX 200-35-BX	200-80-DX 200-80-BX
Membrane Replacement Module	D01-0086	D01-0086
Automatic Drain Kit	21552	21552



# Compressed Air Dryers

## Cabinet Dryers Eliminate Moisture Problems in Electrical Cabinets and Motors

### Balston CD Series Cabinet Dryers

You demand a lot from your electrical cabinets and motors. They are subject to nightly high pressure, hot wash downs and then expected to remain dry in a refrigerated area. Over time most cabinets develop moisture inside which leads to premature component failures. This interrupts production and costs you money. Expensive vortec coolers or heaters don't work. Vortec coolers use a considerable amount of air and have a high operating cost. Heaters simply raise the humidity of the air inside the cabinet and don't eliminate the moisture.

The Parker Balston Cabinet Dryer serves to reduce the humidity inside the cabinet to less than 10% RH. Any water that infiltrates the cabinet evaporates quickly. Electrical components stay clean and dry which prolongs their life.

### Avoid costly down time!

Many plants struggle with moisture problems by managing downtime emergencies. Emergencies divert limited maintenance personnel and disrupt production at the cost of thousands of dollars per hour. The Cabinet Dryer reduces these maintenance and lost production costs by 80% or more. A typical customer will see savings of \$10K - \$15K per year. The Cabinet Dryer will operate continuously and reliably without operator attention thus freeing up valuable maintenance personnel who are better devoted to important routine maintenance work rather than daily emergency response.

### Product Features:

- Designed specifically for wash down areas
- Protects electrical cabinet components from damage caused by water and high humidity
- Minimizes pools of water inside cabinets
- Positive pressure keeps dust out
- Adds no heat to the cabinet
- Reduces cabinet humidity to less than 10% RH
- Requires no electricity, low operating costs
- Easy to install and maintain
- Quiet operation
- Protect motors, touch screens and other critical components



### Do Your Cabinets Look Like This?

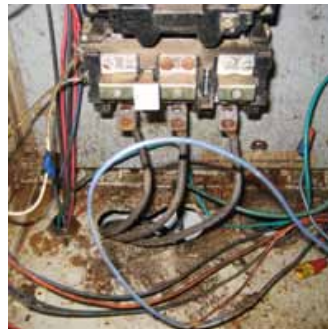

Corrosion leads to premature component failure

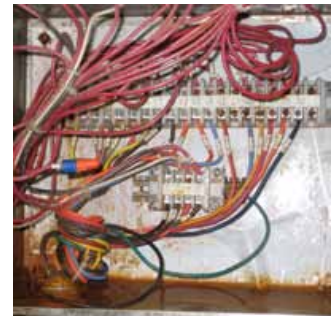

Water accumulation in electrical cabinet

### A Cabinet Dryer will keep your cabinets looking as good as new



# Compressed Air Dryers

## Cabinet Dryers Eliminate Moisture Problems in Electrical Cabinets and Motors

### Principal Specifications

Model Number	CD0005	CD0010	CD0030
Cabinet Size Range*	0 - 4 FT <sup>3</sup>	4 - 12 FT <sup>3</sup>	12 - 36 FT <sup>3</sup>
Min/Max Inlet Air Temp	40°F/120°F	40°F/120°F	40°F/120°F
Min/Max Ambient Air Temp	35°F/120°F	35°F/120°F	35°F/120°F
Air Consumption	0.6 SCFM	1.25 SCFM	3.5 SCFM
Min/Max Air Pressure	60 psi/150 psi	60 psi/150 psi	60 psi/150 psi
Delivered Dew Point (1)	-7°F/-22°C	-7°F/-22°C	-7°F/-22°C
Inlet Port Size	1/4" NPT	1/4" NPT	1/4" NPT
Outlet Port Size	1/4" NPT	1/4" NPT	1/4" NPT
Electrical Requirements	None	None	None
Dimensions	3"w x 9.2"h x 2"d	3"w x 15.2"h x 2"d	4.6"w x 15.3"h x 2.9"d
Shipping Weight	1.5 lbs	2 lbs	2.5 lbs

Notes: Delivered dewpoint is specified for saturated inlet air at 100°F (38°C) and 100 psig.

\* If the cabinet is not tightly sealed, consider upsizing to the next module size.

### Ordering Information For assistance call toll free at 800-343-4048, 8AM to 5PM EST

Model Number	CD0005	CD0010	CD0030
Replacement Filter Elements	070-063-BX	070-063-BX	070-063-BX
Replacement Auto Drain	C02-2392	C02-2392	C02-2392

### What our customers say:

"We tried heaters, fans and vortex coolers, our only solution was to use a Parker Balston dryer that continuously purges the cabinet with dry air."

**Lee Clarkson**  
**Ross Industries**



# Compressed Air Dryers

## PSA Air Dryer



Balston  
Compressed Air  
Dryer

**Reduce the dewpoint of compressed air to -100°F (-73°C)**

**Unattended 24 hour operation**

**Lightweight and compact**

**No desiccant to change**

### Applications

Pneumatic Tool Stations  
HVAC Systems  
Purge Electrical Boxes  
Air Lines Subject to Sub-Freezing Temperatures  
Blanketing Moisture Sensitive Materials  
Spray Painting  
Pneumatic Instrumentation  
Robotics  
Lasers  
Dry Boxes

### Model 75-A20NA

Balston regenerative PSA desiccant dryer reduces the atmospheric dewpoint of compressed air without operator attention. Model 75-A20NA will reduce the dewpoint to -100°F (-73°C). The dryer is delivered complete and ready for easy installation. The dryer has coalescing prefilters with automatic drains, PSA drying towers, a particulate final filter, a moisture indicator, differential pressure indicator, and pretested controls.

The Balston regenerative dryer has safe, 12 VDC electrical controls. To install, simply attach the inlet (60 psig minimum) and outlet air lines, plug the electrical transformer into a wall outlet - no electrician required - and the unit is ready for trouble-free operation.

This reliable dryer can be easily installed, operated, and maintained by personnel not trained in instrumentation. The Balston dryer is useful when air comes into contact with moisture-sensitive materials, or when outside compressed air lines are subjected to sub-freezing temperatures.

The 75-A20NA is a wall mountable unit. It has a 10 SCFM/min. capacity (at 100 psig inlet pressure).

# Compressed Air Dryers

## PSA Air Dryer

### Principal Specifications

Model	75-A20NA
Dewpoint (1)	-100°F (-73°C)
Max. Dry (outlet) Air Flow Rate for Specified Dew Point (1)	
Inlet Pressure 125 psig	12.0 SCFM (340 lpm)
Inlet Pressure 100 psig	10.0 SCFM (283 lpm)
Inlet Pressure 80 psig	8.3 SCFM (235 lpm)
Inlet Pressure 60 psig	6.5 SCFM (184 lpm)
Air Loss for Regeneration (2)	2.5 SCFM (71 lpm)
Min/Max Inlet Air Pressure	60 psig/125 psig
Max. Inlet Air Temperature (3)	78°F (25°C)
Pressure Drop at Max. Flow Rate	8 psi
Inlet/Outlet Port Size (female)	1/4" NPT
Electrical Requirements (4)	120 VAC/60 Hz.
Shipping Weight	50 lbs. (23 kg)
Dimensions	15"W X 41"H (38cm X 104cm)

#### Notes:

1 Dewpoint will be lower than specified at lower air flow.

2 Total air required = air loss for regeneration + process demand (up to max. dry air flow rate).

3 Outlet dewpoint will increase at higher inlet compressed air temperatures.

4 Power consumption - less than 10 watts. Each dryer is shipped with a 12 VDC plug-in transformer to connect to the local electrical supply.

### Ordering Information

For Assistance, call toll-free at 1-800-343-4048 8AM to 5PM Eastern Time

Description	Model Number
Balston Compressed Air Dryer	75-A20NA
Replacement Filter Cartridges 1st stage (box of 10)	100-18-DX
Replacement Filter Cartridges 2nd stage (box of 10)	100-18-BX
Maintenance Kit, 1 year supply of filter cartridges	MK7525P



## North America

### Engine Filtration

Parker Hannifin Corporation  
**Racor Division**  
3400 Finch Road  
P.O. Box 3208  
Modesto, CA 95354  
phone 209 521 7860  
fax 209 529 3278  
www.parker.com/racor

Parker Hannifin Corporation  
**Racor Division**  
P.O. Box 6030  
Holly Springs, MS 38635  
phone 662 252 2656  
fax 662 274 2118  
www.parker.com/racor

Parker Hannifin Corporation  
**Racor Division**  
302 Parker Drive  
Beaufort, SC 29906  
phone 843 846 3200  
fax 843 846 3230  
www.parker.com/racor

### Compressed Air Treatment

Parker Hannifin Corporation  
**Filtration and Separation Division**  
**Balston Operation**  
242 Neck Road  
Haverhill, MA 01835-0723  
phone 978 858 0505  
fax 978 556 7501  
www.balstonfilters.com

Parker Hannifin Corporation  
**Filtration and Separation**  
**Finite Filter Operation**  
500 Glaspie Street  
P.O. Box 599  
Oxford, MI 48371-5132  
phone 248 628 6400  
fax 248 628 1850  
www.parker.com/finitefilter

Parker Hannifin Corporation  
**Airtek Division**  
4087 Walden Avenue  
Lancaster, NY 14086  
phone 716 685 4040  
fax 716 685 1010  
www.airtek.com

### Hydraulic Filtration

Parker Hannifin Corporation  
**Hydraulic Filter Division**  
16810 Fulton County Road #2  
Metamora, OH 43540-9714  
phone 419 644 4311  
fax 419 644 6205  
www.parker.com/hydraulicfilter

### Process Filtration

Parker Hannifin Corporation  
**Process Advanced Filtration**  
2340 Eastman Avenue  
Oxnard, CA 93030  
phone 805 604 3400  
fax 805 604 3401  
www.parker.com/processfiltration

## Europe

### Engine Filtration

Parker Hannifin Corporation  
**Filter Division Europe**  
Shaw Cross Business Park  
Churwell Vale  
Dewsbury, WF12 7RD England  
phone +44 (0) 1924 487000  
fax +44 (0) 1924 487038  
www.parker.com/rfde

### Compressed Air Treatment

Parker Hannifin Corporation  
**domnick hunter industrial operations**  
Dukesway, Team Valley Trading Estate  
Gateshead, Tyne & Wear  
England NE11 0PZ  
phone +44 (0) 191 402 9000  
fax +44 (0) 191 482 6296  
www.domnickhunter.com

Parker Hannifin Corporation  
**Parker Hiross S.p.A.**  
Strada Zona Industriale, 4  
35020, S. Angelo di Piove(PD), Italy  
phone +39 049 9712 111  
fax +39 049 7001 111  
www.dh-hiross.com

Parker Hannifin Corporation  
**ZANDER Aufbereitungstechnik GmbH**  
Stammhaus Essen/Headquarter  
Germany, Essen  
Im Teelbruch 118  
45219 Essen  
phone +49 (0) 20 54 93 40  
fax +49 (0) 20 54 93 41 64  
www.zander.de

### Hydraulic Filtration

Parker Hannifin Corporation  
**Hydraulic Filtration Division Europe**  
Stieltjesweg 8, 6827 BV Arnhem  
P.O. Box 5008 6802 EA, Arnhem  
Arnhem, Holland  
phone +31 26 3760376  
fax +31 26 3643620  
www.parker.com/hfde

Parker Hannifin Corporation  
**Finn Filter Operation**  
Salmentie 260  
FI-31700 Urjala as Finland  
phone +358 20 753 2500  
fax +358 20 753 2501  
www.parker.com/hfde

Parker Hannifin Corporation  
**CMC Operation**  
Brunel Way  
Thetford, Norfolk IP 24 1HP England  
phone +44 1842 763299  
fax +44 1842 756300  
www.parker.com/hfde

### Process Filtration

Parker Hannifin Corporation  
**domnick hunter process division**  
Durham Road, Birtley  
Co. Durham, DH3 2SF England  
phone +44 (0) 191 410 5121  
fax +44 (0) 191 410 5312  
www.domnickhunter.com

## Asia Pacific

Parker Hannifin Corporation  
**Shanghai Co. Ltd.**  
280 YunQiao Road  
JinQiao Export Processing Zone  
Shanghai 101206 China  
phone +86 21 5031 2525  
fax +86 21 5834 3714  
www.parker.com/china

Parker Hannifin Corporation  
**Singapore Pte Ltd.**  
Lot 558A, Jalan Subang 3  
Off Persiaran Subang  
Sungai Penaga Industrial Park  
47610 Subang Jaya  
Selangor Darul Ehsan, Malaysia  
phone +60 3 5638 1476  
fax +60 3 5638 1527  
www.parker.com/malaysia

Parker Hannifin Corporation  
**Thailand Co. Ltd.**  
1023 3rd Floor, TPS Building  
Pattanakam Road  
Suanluang, Bangkok 10250 Thailand  
phone +66 2717 8140  
fax +66 2717 8148  
www.parker.com/thailand

Parker Hannifin Corporation  
**Korea Ltd.**  
777 Jung-Ri  
Dongtan-Myeon, Hwaseong-City  
Kyunggi-Do, 445-813 Korea  
phone +82 31 379 2200  
fax +82 31 377 9710  
www.parker.com/korea

## Latin America

Parker Hannifin Corporation  
**Comercio Ltda. Filtration Division**  
Estrada Municipal Joel de Paula, 900  
Eugenio de Melo, Sao Jose dos Campos  
CEP 12225-390 SP Brazil  
phone +55 (12) 4009 3500  
fax +55 (12) 4009 3529  
www.parker.com/br

© 2008 Parker Hannifin Corporation  
April 2009

## Bulletin FNS-D

Parker Hannifin Corporation  
**Filtration and Separation Division**  
242 Neck Road, P.O. Box 8223  
Haverhill, MA 01835-0723  
1-978-858-0505  
1-978-556-7501 fax  
1-800-343-4048 (US & Canada)  
www.balstonfilters.com

